

CONVOGLIATORI BIROTAIA

B.R. KX 500

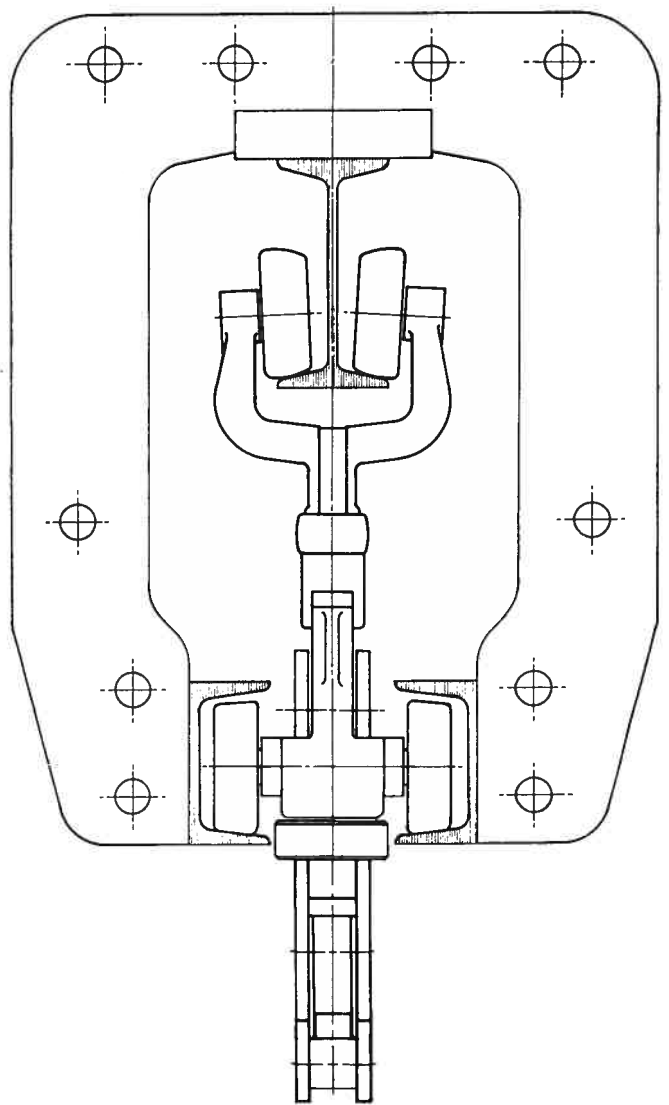

LINEA RETTILINEA BIROTAIA

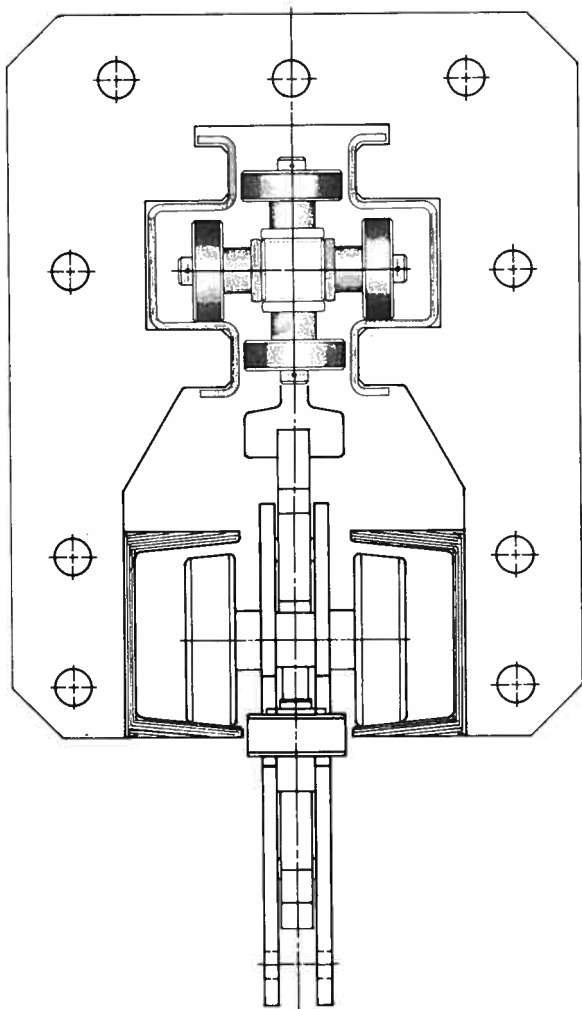
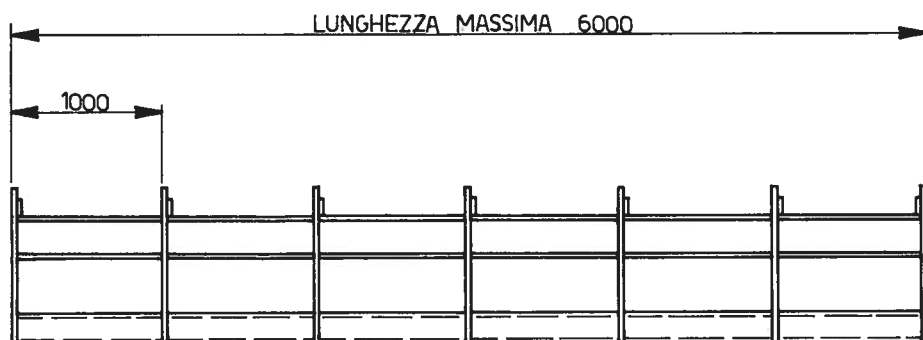

TIPO	A	B	C	D	E	F	H
BRKX500	510	394	280	100	76	176	140

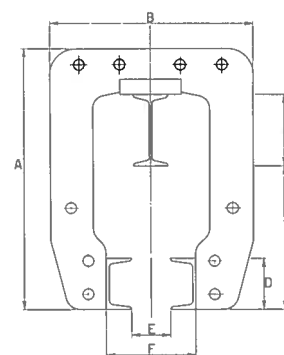

CARRELLI PER LINEA BIROTAIA

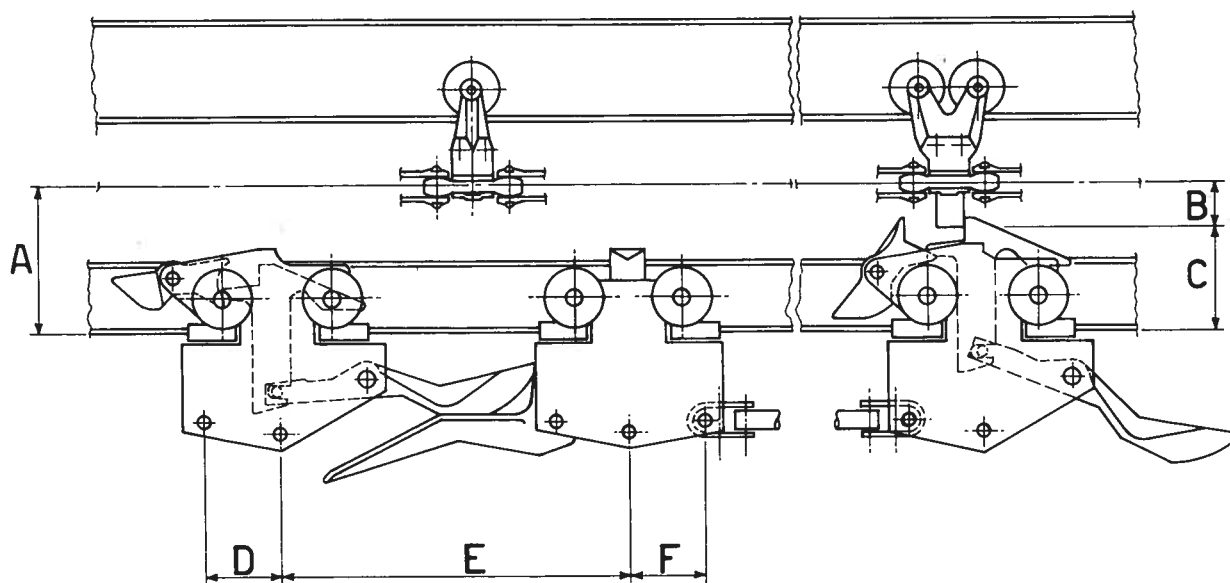

TIPO	A	B	C	D	E	F
BRKX500	190	64	126	102,5	484	90

CURVE ORIZZONTALI

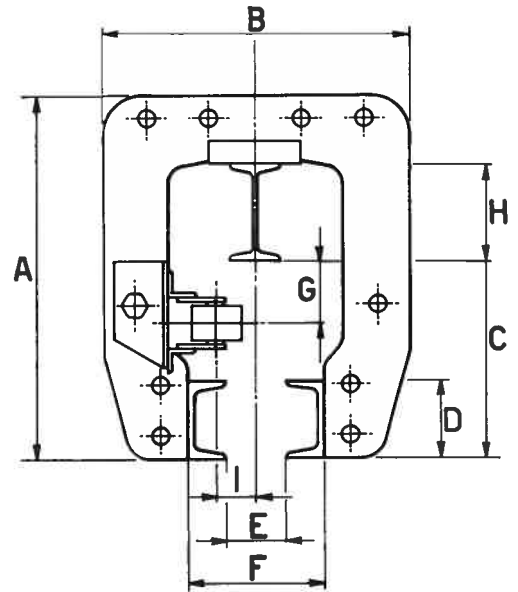
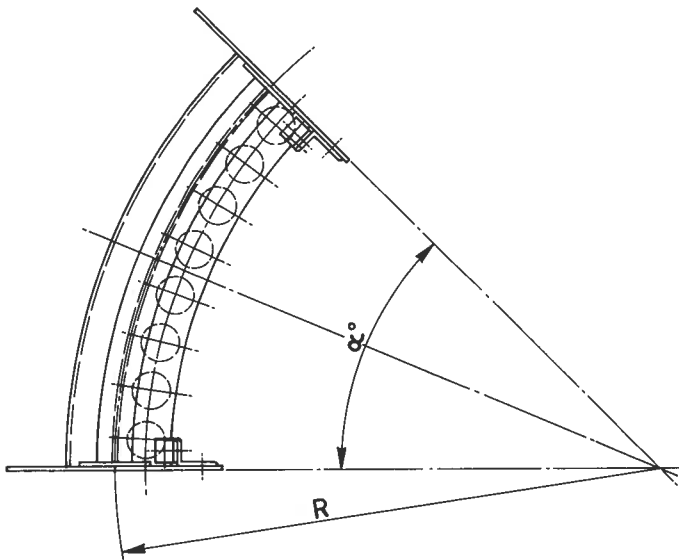

BRKX500	
R	1000 - 1500
α	15 - 30 - 45 - 60 - 90 - 180

TIPO	A	B	C	D	E	F	G	H	I
BRKX500	510	394	280	100	76	176	90	140	54

DISLIVELLI VERTICALI

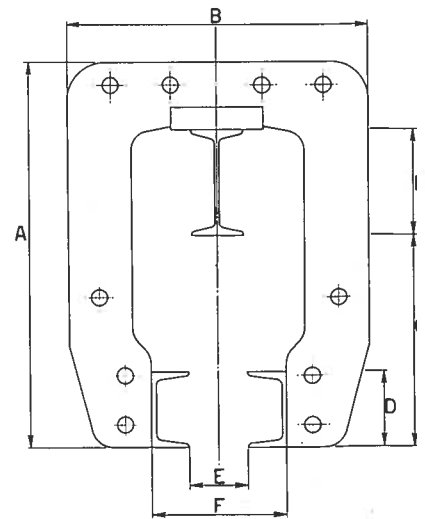
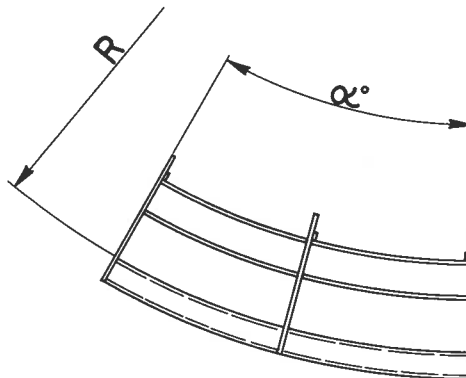
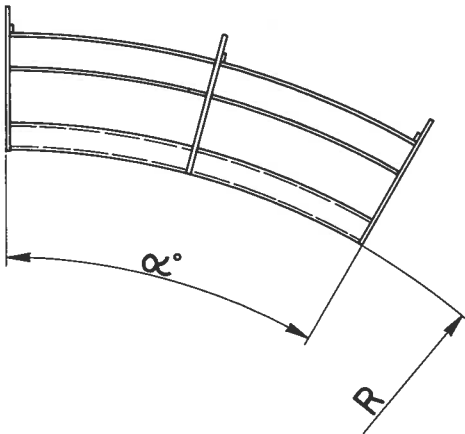

BRKX500	
R	2000 - 3000
α	15 - 30

COMANDO CATERPILLAR

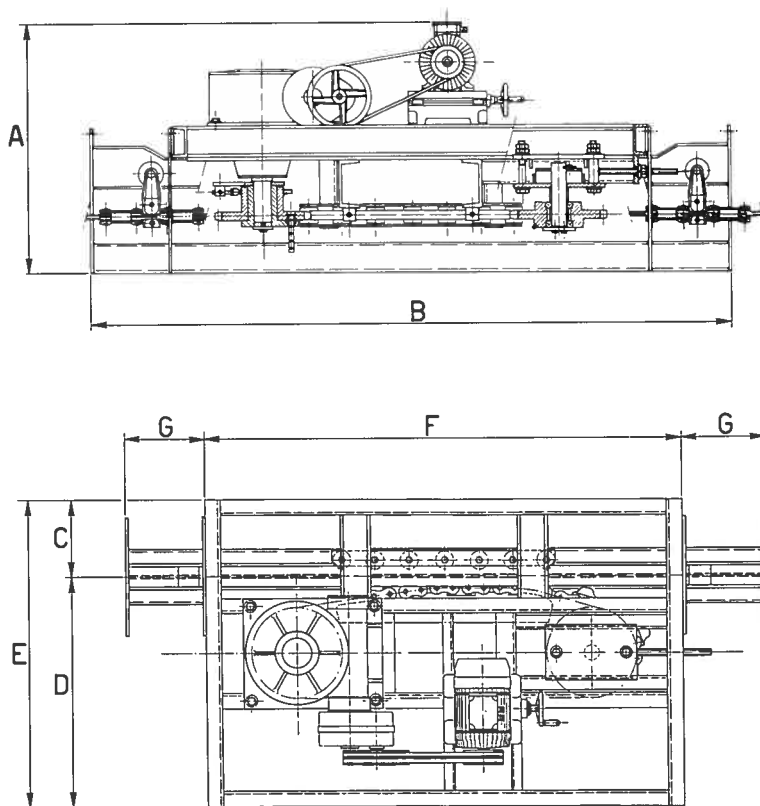

TIPO	BRKX500
A	1200
B	2020
C	275
D	765
E	1030
F	1460
G	280

CATENA PER CATERPILLAR

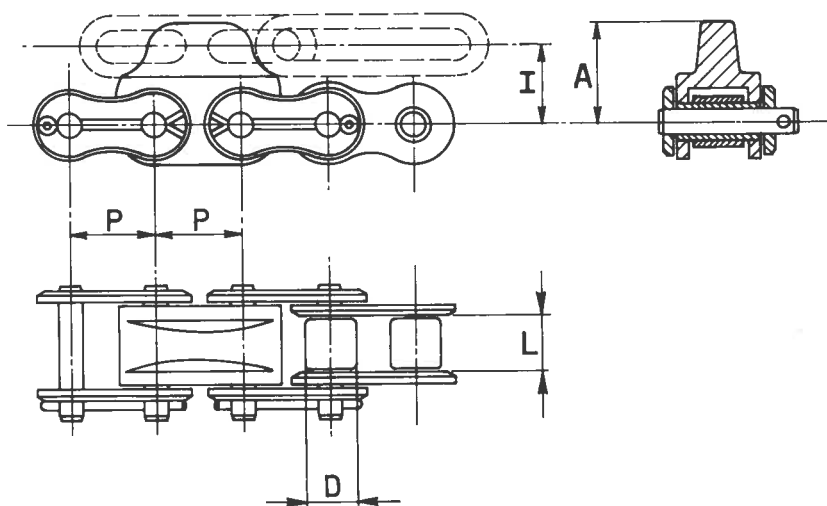

NOSTRO NUMERO	PER CATENA STAMPATA n.	SPINTORE n°	DIMENSIONI NOMINALI			SPINTORE		PESO NETTO AL M. kg.	SVILUPPO mm.
			passo	diam. max. rullo	largh. int.	I	A		
			P mm.	D mm.	L mm.	mm.	mm.		
ASA 160	4" - 458	15	50,8	28,58	31,75	43,5	59	12	3048

TENDITORE A VITE

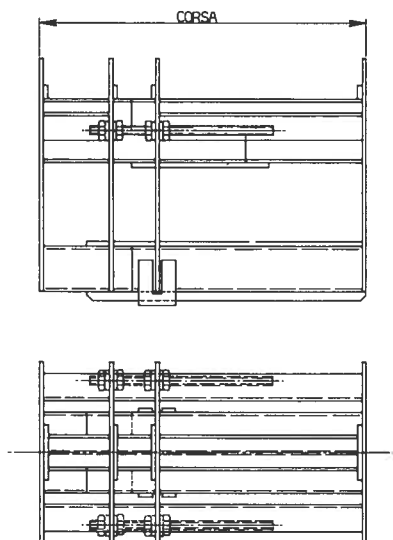

TIPO	CORSA MINIMA	CORSA MASSIMA
BRKX500	710	940

STAZIONE DI STOP

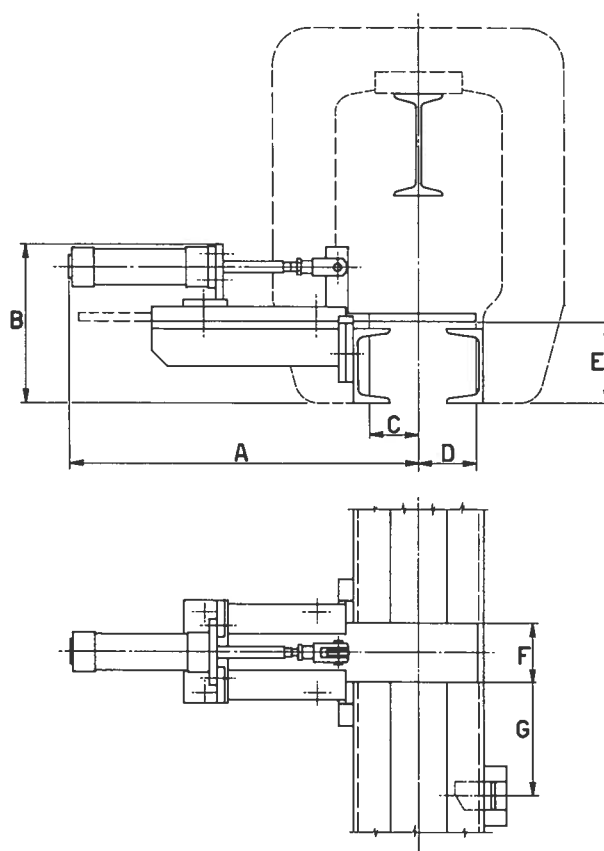

TIPO	BRKX500
A	540
B	240
C	72
D	78
E	109
F	80
G	230



LUBRIFICATORE

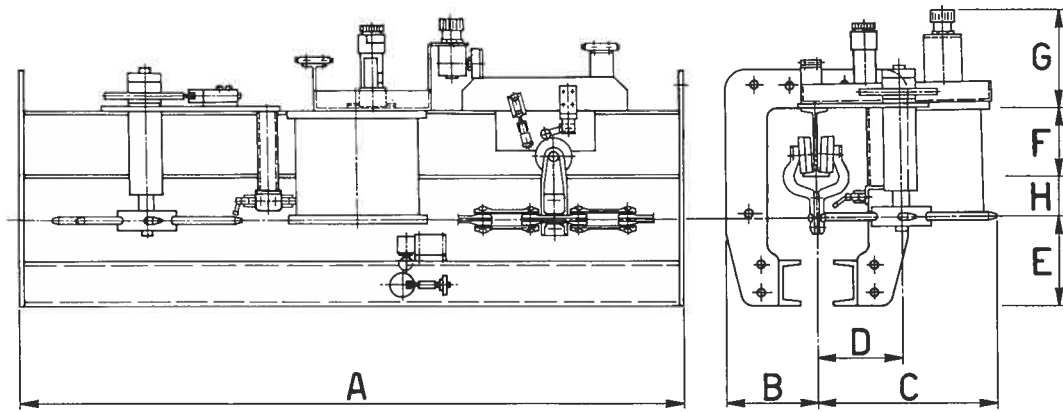

TIPO	A	B	C	D	E	F	G	H
BRKX500	1000	197	430	200	190	140	150	90

SCAMBI

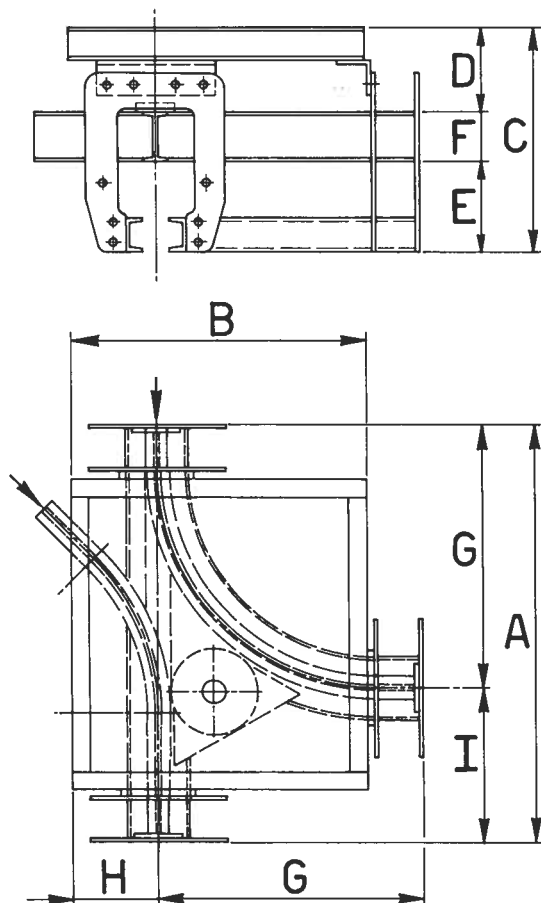

TIPO	BRKX500
A	1200
B	850
C	615
D	195
E	280
F	140
G	750
H	250
I	450